



BV830 three way valve for flow mixing applications. The valve can also be used for flow splitting if the flow is in reverse



BV831 three way valve for flow splitting applications

DESCRIPTION

The BV830/831 valves are designed for either blending two different flows or for dividing a flow into two proportional amounts. The valves can be used on a wide range of process applications for air, water, steam, oil, gases and chemical services.

The BV830 has two inlets and a common outlet branch. It is used for proportional blending of two flows into one stream, on such applications as control of process fluid temperature downstream of heat exchangers, or as mixing valves to control the composition of service media. It can also be used for flow splitting duties. The total capacity is constant irrespective of plug position.

The BV831 series valves are used for proportional control on flow splitting applications. This valve has two outlets and a common inlet branch. They are used for proportional flow splitting, diverting a portion of the process medium from one part of a system to another. A typical application is on the upstream side of heat exchangers to control the temperature of the process fluid.

DESIGN FEATURES

- Top and skirt guided
- Wide range of trim sizes
 - High capacity
 - High stability
 - Balanced

PRESSURE RATING

- Class 150LB to 1500LB
- PN10 to PN250
- ANSI 2500

SIZES

- 40mm to 400mm
1 1/2" to 16"

TRAVELS

- 28.5mm to 89mm
1 1/8" to 3 1/2"

END CONNECTIONS

- Flanged
- Butt weld (on special request)
- Socket weld (on special request)
- Screwed (on special request)

TRIM OPTIONS

"V" Port Standard Trim

The standard trim design for three way applications is the "V" port plug. This design provides high flow capacity, high rangeability and good leakage capability (ANSI class IV). Other trim options are available as semi-special in the three way valve.

Characteristics

- Linear
- Equal percentage (special applications)
- Linear cascade (multi-stage)

Seat Options

- Metal to metal
- Soft face
- Hard faced

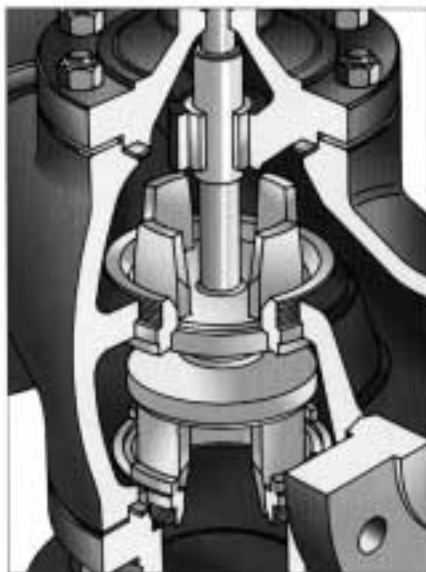

BV830 valve standard contour trim



BV831 valve standard contour trim

BV830/BV831 Valves with soft face trim

The soft face trim option is specified on applications where bubble tight closure is required.

The soft seal is fitted into the plug head and retained by a shroud. The seat is designed with a lip so that when the plug head contacts the seat high integrity of valve closure is achieved.

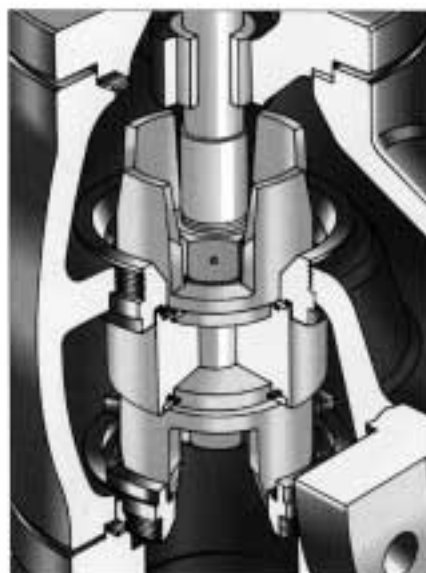

BV830 valve with soft face trim

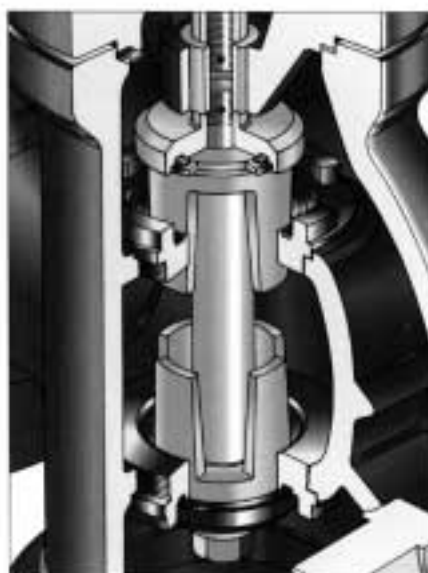

BV831 valve with soft face trim

Severe Service Trim

Specialist severe service trims can be accommodated within the BV830 body design.

The cascade trim is normally used for applications where the flow requires treatment at source to prevent cavitation and high noise levels on high pressure drop liquid and gas applications.

- Low noise
- Anti cavitation
- Low pressure recovery

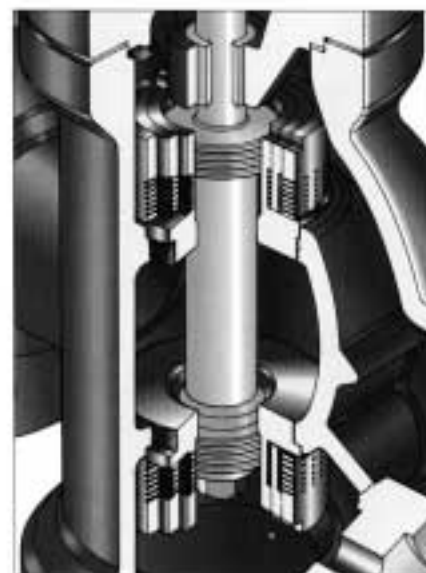

BV831 valve with cascade trim

FLOW DIRECTION

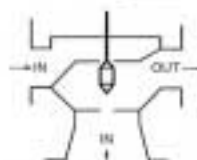

BV830
Normal Flow
Mixing (Blending)

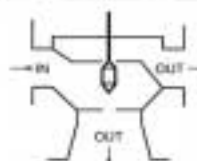

BV830
Reverse Flow
Splitting (Diverting)

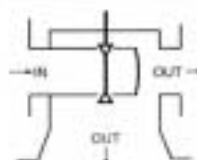

BV831
Normal Flow
Splitting (Diverting)

BONNET FORMS

Standard

For applications where the temperature of the controlled fluid is between $-18\text{ }^{\circ}\text{C}$ ($0\text{ }^{\circ}\text{F}$) and $232\text{ }^{\circ}\text{C}$ ($450\text{ }^{\circ}\text{F}$). May be used with graphite packing up to $315\text{ }^{\circ}\text{C}$ ($600\text{ }^{\circ}\text{F}$). Although modern packings are suitable for much higher temperatures, it is recommended that the normalising bonnet be fitted in cases where the temperatures exceed the above values to accommodate lagging of the control valve body.

Normalising

For protection of the gland packing at temperatures above $232\text{ }^{\circ}\text{C}$ ($450\text{ }^{\circ}\text{F}$) and below $-18\text{ }^{\circ}\text{C}$ ($0\text{ }^{\circ}\text{F}$) down to $-100\text{ }^{\circ}\text{C}$ ($-150\text{ }^{\circ}\text{F}$). The bonnet is designed with fins which dissipate the heat from the process fluid and help protect the packings and actuator assembly from high temperatures. In addition the normalising bonnet is longer than the standard plain bonnet so that the valve can easily be lagged without interference with the actuator.

Bellows Seal

A positive leakproof stem seal for cases where gland leakage cannot be permitted. The standard bellows material is 321 stainless steel, although many other materials are available on request. The design consists of a welded flexible steel bellows which is clamped in an extended bonnet/bonnet hood. This effectively cuts out any possible leakage path around the plug stem and therefore prevents emissions from the valve packings. Packing are fitted in these valves but they only act as a backup for the bellows.

Cryogenic

Used for temperatures below $-100\text{ }^{\circ}\text{C}$ ($-150\text{ }^{\circ}\text{F}$). This is designed with a long necked section which distances the packing away from the process fluid. The necked section is designed with a minimum wall section to minimise heat transfer. Cold box extension/cryogenic bonnets are also available.

PACKING

Packings are selected based on fluid temperature and fluid type. The most common packing system materials are PTFE for low temperature and graphite for high temperature. For hydrocarbons service and where emission levels need to be controlled there are two further types of packings available. These incorporate specially selected materials and live loading to both minimise emissions and extend packing life allowing for cyclic operation. These packings are referred to as LTEP and HTEP.

Packings have been tested to prove emission levels of less than 500 parts per million over 50,000 cycles and under thermal cycling conditions.

PTFE Chevron packing is used for applications where the temperature is between cryogenic to $232\text{ }^{\circ}\text{C}$ ($450\text{ }^{\circ}\text{F}$)

Grafoil packing is used on high temperature applications where the temperature exceeds $232\text{ }^{\circ}\text{C}$ ($450\text{ }^{\circ}\text{F}$)

LTEP low emission packing, temperatures below $260\text{ }^{\circ}\text{C}$ ($500\text{ }^{\circ}\text{F}$)

HTEP low emission packing, temperatures above $260\text{ }^{\circ}\text{C}$ ($500\text{ }^{\circ}\text{F}$)

Other packing types can be accommodated as required.



PTFE Chevron



Grafoil



LTEP - Carbon filled
PTFE Chevron



HTEP - Graphite wedge rings

THREE WAY VALVES BV830 & BV831

VALVE SELECTION GUIDELINES

Valve flow co-efficient

All valves are sized using the valve flow co-efficient, CV, in accordance with ISA 75.01 as detailed in the Blakeborough sizing and selection manual. Design CV values are given in table 4.

Body Selection

The valve body size and style is selected on the basis of supporting the selected trim design and design CV. In addition consideration is made of the velocity and the required pressure drop application. Liquid velocities are limited mainly due to erosion considerations, whereas gas/vapour flow velocities are limited for trim stability noise and vibration considerations.

Trim Selection

The selection criteria of the valve trim ranges from valve flow co-efficient, rangeability, pressure drop, cavitation, flashing and noise consideration. Blakeborough sizing and selection manual details the various calculation methods and selection limitations for each trim design.

TABLE 1 – STANDARD MATERIAL COMBINATIONS

Body Bonnet Bottom Flange	Carbon Steel – Cast or Wrought	Chrome Moly Steel	304 or 304L ST.ST.	347 ST.ST.	316 ST.ST.	Hastelloy B or C	Monel	Alloy 20	Duplex
Body Gasket	316 ST.ST.	316 ST.ST.	316 ST.ST.	316 ST.ST.	316 ST.ST.	PTFE	PTFE	PTFE	PTFE
Body Studs/Nuts	B7/2H	B7/2H or B16/7	B8/8	B8/8	B8/8	B8/8	B8/8	B8/8	B8/8

TABLE 2 – TRIM MATERIAL COMBINATIONS

Plug	316 ST.ST.	316 Stellite Faced	316 Full Stellite	Hastelloy B/C	Monel 400	Alloy 20	17-4PH ST.ST.	NACE 316 ST.ST.	Duplex
Seat	316 ST.ST.	316 Stellite Faced	316 Full Stellite	Hastelloy B/C	Monel 400	Alloy 20	17-4PH ST.ST.	316 ST.ST.	Duplex
Stem	316 ST.ST.	316 ST.ST.	316 ST.ST.	Hastelloy B/C	Monel 400	Alloy 20	316 ST.ST.	316 ST.ST.	Duplex
Guide Bush	440C ST.ST.	440C ST.ST.	Stellite	Stellite	Monel K500	Stellite	440C ST.ST.	Stellite	Stellite
Packing Parts	316 ST.ST.	316 ST.ST.	316 ST.ST.	Hastelloy B/C	Monel 400	Alloy 20	316 ST.ST.	Monel 400	Duplex

PTFE GASKETS ARE SUITABLE FOR TEMPERATURES UP TO 450°F (232°C) ABOVE THIS, MATERIAL SPECIFICALLY CONSIDERED. MATERIAL LISTED ARE STANDARD COMBINATIONS ONLY ANY OTHER MATERIAL COMBINATION CAN BE ACCOMMODATED. TRIM MATERIALS SPECIFIED CAN BE SUPPLIED TO CONFORM TO NACE. SPEC. MR-01-75 MATERIAL CAN BE SUPPLIED TO UOP SPEC. OTHER MATERIAL COMBINATIONS AVAILABLE

TABLE 3 – RECOMMENDED LIMITING INLET VELOCITIES FOR CONTROL VALVES

VALVE SIZE	LIQUID m/s	LIQUID ft/s	STEAM or GAS m/s	STEAM or GAS ft/s	MAX OUTLET (STEAM or GAS)
40 & 50mm (1 1/2" & 2")	12	40	105	350	0.65 x SONIC
80 & 100mm (3" & 4")	11	36	100	315	
150 & 200mm (6" & 8")	10.5	30	90	275	
250 to 300mm (10" to 16")	7.5	25	70	225	

NOTE: 0.3 SONIC FOR LOW NOISE APPLICATIONS.

THREE WAY VALVES BV830 & BV831

**TABLE 4 – FLOW COEFFICIENTS,
CV (US UNITS)**

TRIM TYPE	BODY SIZE	BV830 FULRATE	BV831 FULRATE
LINEAR	40mm (1 1/2")	27	27
	50mm (2")	40	40
	80mm (3")	90	90
	100mm (4")	145	130
	150mm (6")	300	340
	200mm (8")	550	500
	250mm (10")	775	725
	300mm (12")	1200	1100
	400mm (16")	2200	2100

**TABLE 5 – NORMAL CONTROL
VALVE LEAKRATES**

TRIM STYLE	ANSI LEAKAGE CLASS	MAXIMUM ALLOWABLE LEAKAGE
Unbalanced Metal to Metal	Class IV	0.01% Rated Capacity
Unbalanced Metal to Metal Lapped Seats	Class V	0.0005 ml of water per inch of port diameter per PSI differential
Unbalanced Soft Face	Class VI	Bubble Tight

TABLE 6 – VALVE DIMENSIONS

		40mm (1 1/2")	50mm (2")	80mm (3")	100mm (4")	150mm (6")	200mm (8")	250mm (10")	300mm (12")	400mm (16")
Up to ANSI 300lb and PN40	F	235 (9 1/4)	267 (10 1/2)	317 (12 1/2)	368 (14 1/2)	473 (18 5/8)	568 (22 3/8)	718 (28 1/4)	775 (30 1/2)	940 (37)
	G	157 (6 3/16)	168 (6 5/8)	200 (7 7/8)	216 (8 1/2)	273 (10 3/4)	306 (12 1/16)	413 (16 1/4)	433 (17)	538 (21)
	H	187 (7 3/8)	200 (7 7/8)	232 (9 1/8)	273 (10 3/4)	319 (12 9/16)	379 (14 15/16)	540 (21 1/4)	562 (22 1/8)	635 (25)
ANSI 600lb and PN100	F	251 (9 7/8)	286 (11 1/4)	337 (13 1/4)	394 (15 1/2)	508 (20)	610 (24)	762 (30)	820 (32 1/4)	990 (39)
	G	164 (6 7/16)	178 (7)	229 (9)	267 (10 1/2)	319 (12 9/16)	368 (14 1/2)	440 (17 5/16)	455 (17 13/16)	533 (21)
	H	195 (7 11/16)	210 (8 1/4)	260 (10 1/4)	324 (12 3/4)	367 (14 7/16)	435 (17 1/8)	562 (22 1/8)	584 (23)	660 (26)
Up to ANSI 300lb Ring joint	F	248 (9 3/4)	283 (11 1/8)	333 (13 1/8)	384 (15 1/8)	489 (19 1/4)	584 (23)	733 (28 7/8)	791 (31 1/8)	956 (37 5/8)
	G	160 (6 5/16)	172 (6 3/4)	204 (8)	220 (8 5/8)	277 (11)	310 (12 1/8)	417 (16 3/8)	437 (17 1/4)	515 (20 1/4)
	H	190 (7 1/2)	204 (8)	236 (9 1/4)	277 (10 7/8)	323 (12 11/16)	383 (15 1/16)	565 (22 1/4)	565 (22 1/4)	638 (25 1/8)
ANSI 600lb Ring joint	F	251 (9 7/8)	289	340	397	511	613	765	823	993 (39 1/8)
	G	167 (6 9/16)	181 (7 1/8)	232 (9 1/8)	270 (9 1/4)	322 (12 11/16)	371 (14 5/8)	445 (17 7/16)	458 (18)	536 (21 1/8)
	H	196 (7 3/4)	211 (8 5/16)	261 (10 5/16)	325 (12 3/16)	368 (14 1/2)	436 (17 3/16)	563 (22 3/16)	585 (23 1/16)	661 (26 1/16)
Plain (J)	J	159 (6 1/4)	165 (6 1/2)	203 (8)	194 (7 5/8)	311 (12 1/4)	376 (10 7/8)	349 (13 3/4)	CF	CF
Normalising (I)	I	283 (11 1/8)	295 (11 5/8)	321 (12 5/8)	343 (13 1/2)	419 (16 1/2)	422 (16 5/8)	591 (23 1/4)	CF	CF
Plain (L)	L	191 (7 1/2)	197 (7 3/4)	235 (9 1/4)	251 (9 7/8)	356 (14)	381 (15)	464 (18 1/8)	502 (19 3/4)	689 (27 1/8)
Normalising (L)	L	311 (12 1/4)	323 (12 7/8)	352 (13 7/8)	400 (15 3/4)	464 (18 1/4)	530 (20 7/8)	705 (27 3/4)	791 (31 1/8)	1041 (41)
Belows (L)	L	365 (14 3/8)	378 (14 7/8)	464 (18 1/4)	476 (18 3/4)	660 (26)	673 (26 1/2)	895 (35 1/4)	910 (35 7/8)	CF
Valve Travel		28.6 (1 1/8)	28.4 (1 1/8)	38.1 (1 1/2)	38.1 (1 1/2)	57.2 (2 1/4)	57.2 (2 1/4)	88.9 (3 1/2)	88.9 (3 1/2)	88.9 (3 1/2)

CF = CONSULT FACTORY

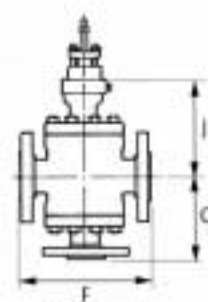

BV830 valve

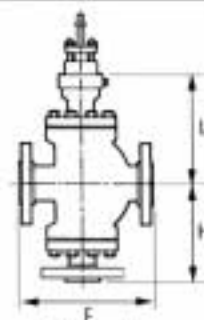

BV831 valve

TABLE 7 - WEIGHTS (FLANGED VALVES - KG)

			40mm (1 1/2")	50mm (2")	80mm (3")	100mm (4")	150mm (6")	200mm (8")	250mm (10")	300mm (12")	400mm (16")
BV830	CLASS 300LB (NP40)	Plain	20	35	50	68	150	253	401	CF	CF
		Norm	22	38	54	73	155	259	411	CF	CF
	CLASS 600LB (NP100)	Plain	22	38	55	95	210	320	510	CF	CF
		Norm	24	44	59	115	255	365	580	CF	CF
BV831	CLASS 300LB (NP40)	Plain	23	34	64	91	186	342	515	823	CF
		Norm	26	38	68	98	192	348	520	835	CF
		Bellows	35	46	85	126	230	405	516	888	CF
	CLASS 600LB (NP100)	Plain	24	37	70	120	228	416	480	836	CF
		Norm	28	41	75	127	234	422	498	850	CF
		Bellows	36	49	91	155	272	479	582	960	CF

CF - CONSULT FACTORY